

Proludic®

Designer of play and sports areas

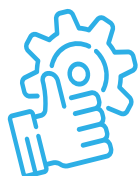

MAINTENANCE TRAINING GUIDE

PROLUDIC.COM

21 nov. 2023

SAFETY STANDARDS	2
ASSEMBLY INSTRUCTIONS.....	3
1 MAINTENANCE OF THE AREA AND ITS ENVIRONMENT	
Safety Surfacing	5
Surrounding Open Spaces.....	5
2 EQUIPMENT MAINTENANCE (BY ELEMENT/BY PRODUCT RANGE)	
WOODEN POSTS	6
LACQUERED PANELS	6
NETS	7
PLATFORMS	7
MULTIPLAY EQUIPMENT	
Diabolo & Diabolo Baby.....	8
Vivarea	9
Kidzy	10
Biiibox.....	11
Ixo	12
Kanopé.....	13
ORIGIN' ROBINIA WOOD EQUIPMENT	14
THEMED EQUIPMENT	
Adventure, Metropolis, City, Aquatica, Medieval.....	15
MOVING EQUIPMENT	
Springers	16
Rotating equipment.....	17
Roll Runner®	19
Cableways.....	20
TRADITIONAL PLAY EQUIPMENT	
Play houses.....	22
Swings.....	23
Slides	24
CLIMBING & BALANCING EQUIPMENT	
Trampolines	25
Balancing trail	26
Rope structures.....	27
Climbing equipment (Pyramids).....	28
The Vertical World	29
The Suspended World.....	30
EDUCATIONAL AND SENSORY EQUIPMENT	
GymLudic®.....	31
Play panels & Audio and musical play.....	32
Water play equipment	33
Sand play equipment	34
Sand Factory	35
Interactive play	36
SPORT	
Multi use games areas	37
Ball Games	38
URBANIX Fitness.....	39
Street Workout.....	40
Vitality Areas.....	41
Trim Trail	42
Rodeoboard®.....	43
Altima®	44
Turnfly®.....	45
Skysurf®.....	46
Hip Hop®.....	47
Cyclogym.....	48
FURNITURE AND SIGNAGE	
Furniture, Fencing, Signage.....	49
3 ORGANISATION OF MAINTENANCE	50

For children, the pleasure of playing is all the greater if the equipment that is provided for their use is in good condition and checked regularly. This means that they can make the most of the facilities.

The durability and safety of a playground depend to a great extent on the servicing and maintenance work carried out, together with the fact, of course, that the products have been designed in accordance with quality principles, as is the case with PROLUDIC products.

SAFETY STANDARDS

Since publication of the European safety standards in 1998 and their subsequent revisions in 2008 and 2017, the obligations to be met by the operating entity and the equipment supplier have been clearly defined in the form of the normative texts EN 1176-1 and EN 1176-7.

The latter determines various checks to be made at specific intervals.

These intervals are given for information purposes only; they must be adapted to suit the frequency of use and the site.

MONTHLY

- Routine visual inspection to identify the risks stemming from acts of vandalism, use or specific weather conditions.
- Ensure all fixings are securely fastened.
- Check for missing or broken parts.
- Ensure that protective covers are in place.
- Check the equipment weight load for loose-fill surfacing.

EVERY 3 MONTHS

- Functional check to make sure that the equipment, or the part concerned, is operating correctly.
- Check all fixings.
- Check the stability of the equipment.
- Inspect wear levels (flooring, bars, chains, cables, etc.).

YEARLY

- Inspect the anchoring systems.
- Clean thoroughly.
- Check the condition of the supporting structure.
- Check the condition of the lacquered plates.

Once these checks have been made, corrective actions must be taken if the results found so require.

The PROLUDIC Maintenance manual is a practical working document that draws on 30 years of experience ; it is made available to our clients and more specifically those responsible for maintenance work on playground equipment for collective use.

For each type of product, we have compiled a list of the inspection to be carried out together with their frequency.

ASSEMBLY INSTRUCTIONS

The first step to be taken is to ensure that the equipment item lasts a long time and can be used by children safely is to make sure that the installation complies with the information supplied in the assembly instructions.

SOME KEY INFORMATION



Definition of the fixings: each assembly requires a specific combination of fixings to ensure its correct installation.

A data sheet is available showing all the types of fixings, permitting an easy identification of each one.

 	<p>VBT 6 x 30 \varnothing L (mm)</p> <p>VFHC</p>	 	<p>VEC M10 \varnothing</p> <p>VEF</p>
 <p>MIN MAX</p> <p>1000 - 1800 tr/min Vitesse de rotation Rotation speed</p>	<p>VTHA</p> <p>14 N.m Couple de rupture Torque of break</p>	 	<p>VEB</p>
	<p>VWT</p>		<p>VR6x18 $\varnothing A$ $\varnothing B$</p>
	<p>VCBHC</p>		<p>VGC</p>
	<p>VBTR</p>	 	<p>M10 440N M10 310 N</p>
	<p>VTRCC</p>	 	<p>M8440N M8310N</p>
	<p>VTH</p>		<p>MI2503</p>
	<p>VTF</p>		<p>MI2701</p>
	<p>VBT</p>		

SOME KEY INFORMATION



- The measurements shown enable assembly in compliance with safety standards.
- The product reference codes enable easy identification.
- The reference codes of the parts or assemblies make it easy to identify an element if a replacement is required.

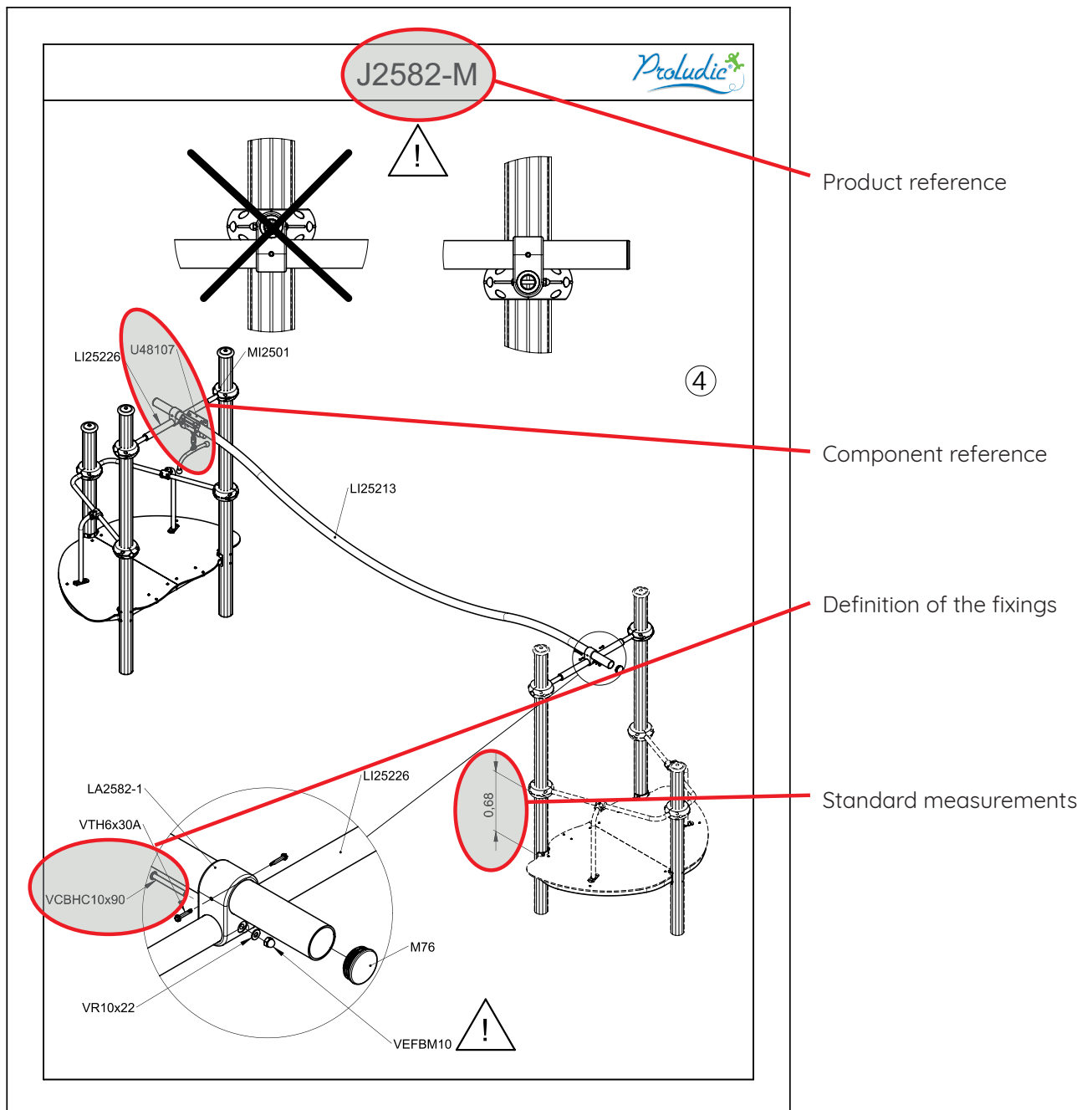

1

MAINTENANCE OF THE AREA AND ITS ENVIRONMENT

A playground is not limited to the items of equipment making it up; it also includes the safety surfacing and its surroundings that must also be maintained to ensure safe use over a long period.

SAFETY SURFACING

There are various types of flooring, including but not limited to synthetic surfaces and loose-fill surfaces. They have to be maintained in order to conserve their characteristics.

MONTHLY

- Rake to remove all unwanted or potentially dangerous objects (loose-fill surfaces).
- Ensure a consistent level (loose-fill surfaces).

EVERY 3 MONTHS

- High-pressure cleaning of rubber floors.

YEARLY

- Loose-fill surfaces: check the thickness of the layer of loose-fill materials and add extra material as necessary.

SURROUNDING OPEN SPACES

- Make sure at regular intervals that the state of the vegetation present in or around the playground does not present a risk to users.
- Cut the vegetation back if necessary to ensure that it does not reach the impact zones of the playground equipment, which must remain free of all obstacles.
- Check the signs in the playground (updating the telephone numbers and addresses of the organizations to be contacted in the event of an accident, if required).



2

EQUIPMENT MAINTENANCE

Each playground has a specific maintenance requirement, according to the elements installed and the materials used.

WOODEN POSTS

MONTHLY

- Ensure that there are no splinters present on wooden posts.



YEARLY

- Check that the wood has not split open and that no layers have come unstuck.
- Check that the posts are in good condition.

COLOURED PANELS

Composite compact panel

Plywood



YEARLY

- Check the overall condition of the lacquered plates. Check for chipped paintwork on the parts most exposed to friction.
- It is essential to touch up paintwork if the colour has been removed (Plywood).
- Clean with water and detergent using a high-pressure cleaner.

NETS

MONTHLY

- Make sure that the linking elements are in place.

YEARLY

- Check the fixings.
- Check the cable for wear. Replace the cable if the metal core is visible.



PLATFORMS

YEARLY

- Check the overall condition of the elements.
- Clean with water and detergent using a high-pressure cleaner.

Composite compact panel

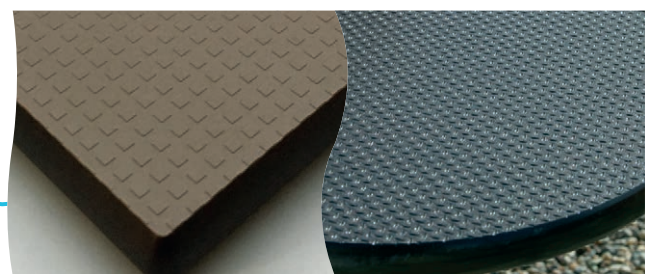

Plywood



MONTHLY

- Routine visual inspection to identify the risks stemming from acts of vandalism, use or specific weather conditions.
- Ensure all fixings are securely fastened.
- Check for missing or broken parts.
- Ensure that protective covers are in place.
- References with a swing: see page 23.

EVERY 3 MONTHS

- Make sure that the equipment, or the part concerned, is operating correctly.
- Check all the fixings.
- Check the stability of the equipment.
- Inspect for wear (flooring, bars, chains, cables, grips, etc.).
- References with a swing: see page 23.

YEARLY

- Inspect the anchoring systems.
- Inspect the condition of the framework.
- Check that the posts are in good condition.
- Check the general condition of the coloured panels.
- Clean the equipment thoroughly.
- References with a swing: see page 23.



MONTHLY

- Routine visual inspection to identify the risks stemming from acts of vandalism, use or specific weather conditions.
- Ensure all fixings are securely fastened.
- Check for missing or broken parts.
- Ensure that protective covers are in place.
- Check that the wooden posts are free from splinters.

EVERY
3 MONTHS

- Make sure that the equipment, or the part concerned, is operating correctly.
- Check all the fixings.
- Check the stability of the equipment.
- Inspect for wear (flooring, bars, chains, cables, grips, etc.).

YEARLY

- Inspect the anchoring systems.
- Inspect the condition of the framework.
- Check that the wooden posts have not split open and that no layers have come unstuck.
- Check that the posts are in good condition.
- Check the general condition of the coloured panels.
- Clean the equipment thoroughly.



MONTHLY

- Routine visual inspection to identify the risks stemming from acts of vandalism, use or specific weather conditions.
- Ensure all fixings are securely fastened.
- Ensure that protective covers are in place.

**EVERY
3 MONTHS**

- Functional check to make sure that the equipment, or the part concerned, is operating correctly.
- Check all the fixings.
- Check the stability of the equipment.
- Inspect for wear (flooring, bars, chains, cables, grips, etc.).

YEARLY

- Inspect the anchoring systems.
- Inspect the condition of the framework.
- Check that the posts are in good condition.
- Check the general condition of the coloured panels.
- Check the general condition of the polyethylene components
- Clean the equipment thoroughly.



MONTHLY

- Routine visual inspection to identify the risks stemming from acts of vandalism, use or specific weather conditions.
- Ensure all fixings are securely fastened.
- Check for missing or broken parts.
- Ensure that protective covers are in place.

**EVERY
3 MONTHS**

- Functional check to make sure that the equipment, or the part concerned, is operating correctly.
- Check all the fixings.
- Check the stability of the equipment.
- Inspect for wear (flooring, bars, chains, cables, grips, etc.).

YEARLY

- Inspect the anchoring systems.
- Inspect the condition of the framework.
- Check that the posts are in good condition.
- Check the general condition of the coloured panels.
- Clean the equipment thoroughly.

G45804

- Check the part MU2513 for wear. Replace if necessary.

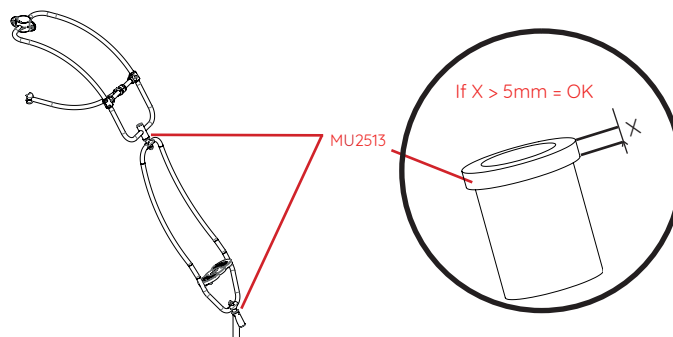

G45821

- Check the fixing between the trolley and the rail.
- Check the wear of the part MU442 located on the handle. Replace if necessary.

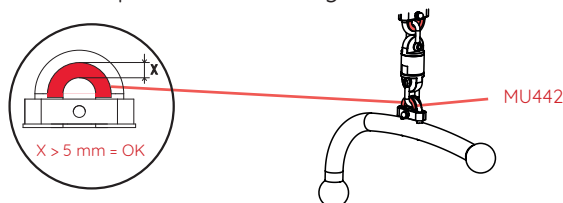



MONTHLY

- Routine visual inspection to identify the risks stemming from acts of vandalism, use or specific weather conditions.
- Ensure all fixings are securely fastened.
- Check for missing or broken parts.
- Ensure that protective covers are in place.
- Check that the wooden posts are free from splinters. (IXO wood version)

EVERY 3 MONTHS

- Make sure that the equipment, or the part concerned, is operating correctly.
- Check all fixings.
- Check the stability of the equipment.
- Inspect for wear (flooring, bars, chains, cables, grips, etc.).

YEARLY

- Inspect the anchoring systems.
- Inspect the condition of the framework.
- Check that the wooden posts have not split open and that no layers have come unstuck.
- Check that the posts are in good condition.
- Check the general condition of the coloured panels.
- Check the general condition of the polyethylene components.
- Clean the equipment thoroughly.

G2515

- Check the part MU2513 for wear. Replace if necessary.

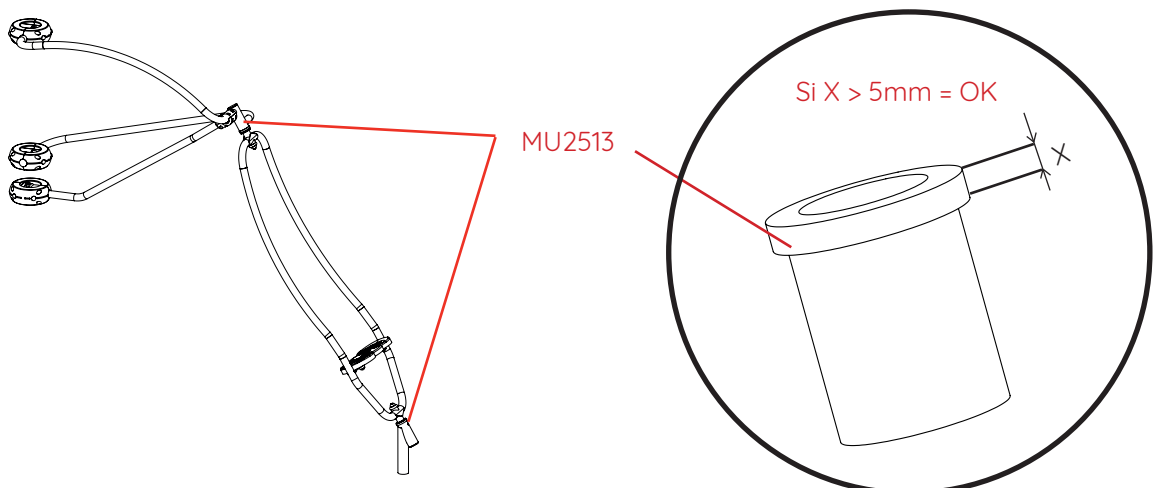



MONTHLY

- Routine visual inspection to identify the risks stemming from acts of vandalism, use or specific weather conditions.
- Ensure all fixings are securely fastened.
- Check for missing or broken parts.
- Ensure that protective covers are in place.
- Check that the wooden posts are free from splinters.

EVERY
3 MONTHS

- Make sure that the equipment, or the part concerned, is operating correctly.
- Check all fixings.
- Check the stability of the equipment.
- Inspect for wear (flooring, chains, cables, grips, rubber coated fabric, etc.).

YEARLY

- Inspect the anchoring systems.
- Inspect the condition of the framework.
- Check that the posts are in good condition.
- Check the general condition of the coloured panels.
- Check the general condition of the polyethylene components.
- Clean the equipment thoroughly.



MONTHLY

- Routine visual inspection to identify the risks stemming from acts of vandalism, use or specific weather conditions.
- Ensure all fixings are securely fastened.
- Check for missing or broken parts.
- Ensure that protective covers are in place.
- Check that the wooden posts are free from splinters.
- Fill in any knots which may have appeared in the wood using wood-pulp, in order to remove any potential finger traps.

EVERY
3 MONTHS

- Make sure that the equipment, or the part concerned, is operating correctly.
- Check all the fixings.
- Check the stability of the equipment.
- Inspect for wear (flooring, bars, chains, cables, grips, etc.).

YEARLY

- Inspect the anchoring systems.
- Inspect the condition of the framework.
- Check that the posts are in good condition.
- Clean the equipment thoroughly.

CITY, ADVENTURE, AQUATICA, METROPOLIS, MEDIEVAL THEMED EQUIPMENT

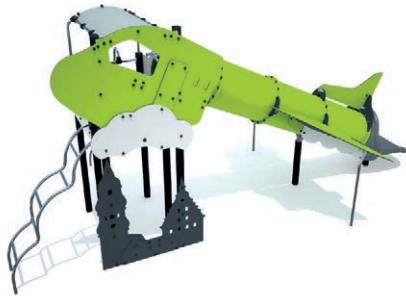

MONTHLY

- Routine visual inspection to identify the risks stemming from acts of vandalism, use or specific weather conditions.
- Ensure all fixings are securely fastened.
- Check for missing or broken parts.
- Ensure that protective covers are in place.
- Check that the wooden posts are free from splinters.

EVERY 3 MONTHS

- Make sure that the equipment, or the part concerned, is operating correctly.
- Check all the fixings.
- Check the stability of the equipment.
- Inspect wear levels (flooring, bars, chains, cables, grips, etc.).

YEARLY

- Inspect the anchoring systems.
- Check the condition of the framework.
- Check that the wooden posts have not split open and that no layers have come unstuck.
- Check that the post is in good condition.
- Check the general condition of the coloured panels.
- Check the general condition of polyethylene parts
- Clean the equipment thoroughly.



MONTHLY

- Routine visual inspection to identify the risks stemming from acts of vandalism, use or specific weather conditions.
- Ensure all fixings are securely fastened.
- Check for missing or broken parts.
- Ensure that protective covers are in place.

EVERY 3 MONTHS

- Make sure that the equipment, or the part concerned, is operating correctly.
- Check all the fixings.
- Check the stability of the equipment.
- Inspect for wear.

YEARLY

- Inspect the anchoring systems.
- Check the general condition of the coloured panels.
- Ensure that no rust is present on the spring(s).
- Clean the equipment thoroughly.

ROTATING EQUIPMENT

MOVING EQUIPMENT

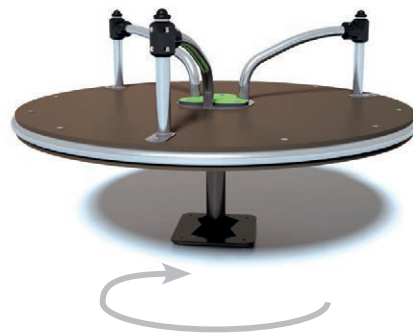

MONTHLY

- Routine visual inspection to identify the risks stemming from acts of vandalism, use or specific weather conditions.
- Ensure all fixings are securely fastened.
- Check for missing or broken parts.
- Ensure that the protective covers are in place.
- Check that the wooden posts are free from splinters.

EVERY 3 MONTHS

- Make sure that the equipment, or the part concerned, is operating correctly.
- Clean the equipment thoroughly.
- Check all fixings.
- Check the stability of the equipment.

YEARLY

- Inspect the anchoring systems.
- Check that the wooden posts have not split open and that no layers have come unstuck (J2594).
- Check that the post is in good condition.
- Check the general condition of the coloured panels.

J2594/
J2594-M

- Check the part MU2513 for wear. Replace if necessary.

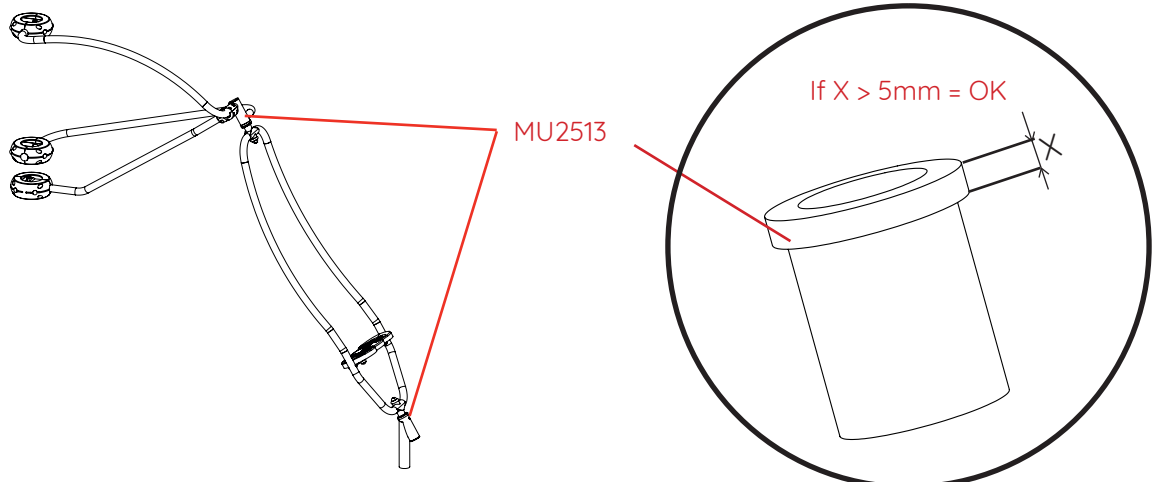



YEARLY

J2409

- Lubrication
- Inspection of the peripheral space (movable plate / chassis)

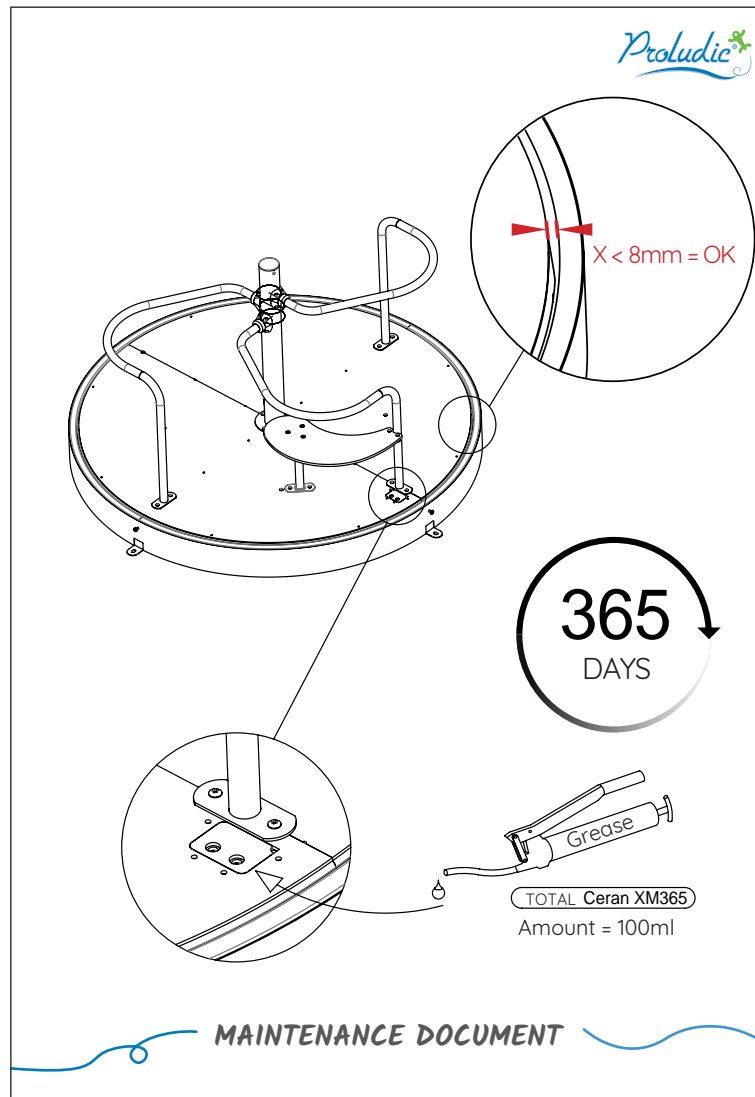

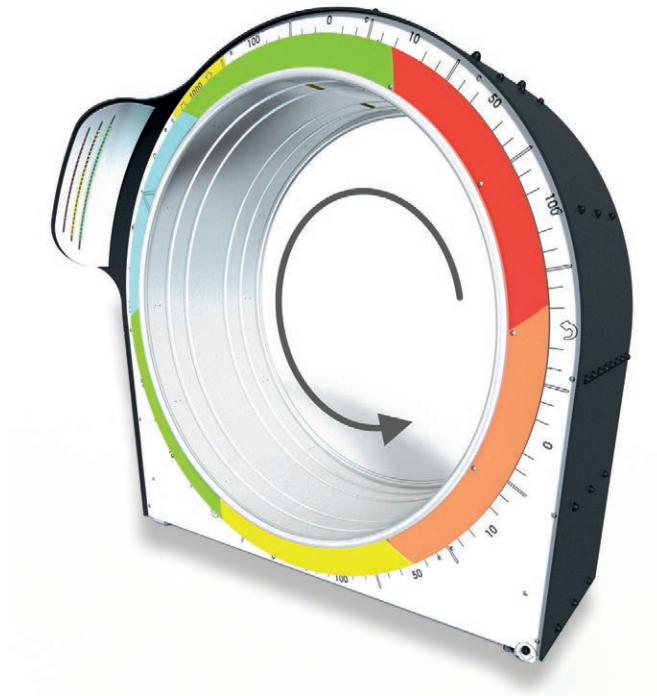

MONTHLY

- Routine visual inspection to identify the risks stemming from acts of vandalism, use or specific weather conditions.
- Ensure all fixings are securely fastened.
- Check for missing or broken parts.
- Ensure that protective covers are in place.

**EVERY
3 MONTHS**

- Ensure all fixings are securely fastened.
- Check for missing or broken parts.
- Ensure that protective covers are in place.

YEARLY

- Inspect the anchoring systems
- Clean the equipment thoroughly

MONTHLY

- Routine visual inspection to identify the risks stemming from acts of vandalism, use or specific weather conditions.
- Ensure all fixings are securely fastened.
- Check for missing or broken parts.
- Ensure that protective covers are in place.
- Check that the wooden posts are free from splinters (J2581 - J2582 - J510 - J511).

EVERY 3 MONTHS

- Make sure that the equipment, or the part concerned, is operating correctly.
- Check all fixings.
- Check the stability of the equipment.

YEARLY

- Inspect the anchoring systems.
- Check that the wooden posts have not split open and that no layers have come unstuck (J2581 - J2582 - J510 - J511).
- Check that the post is in good condition.

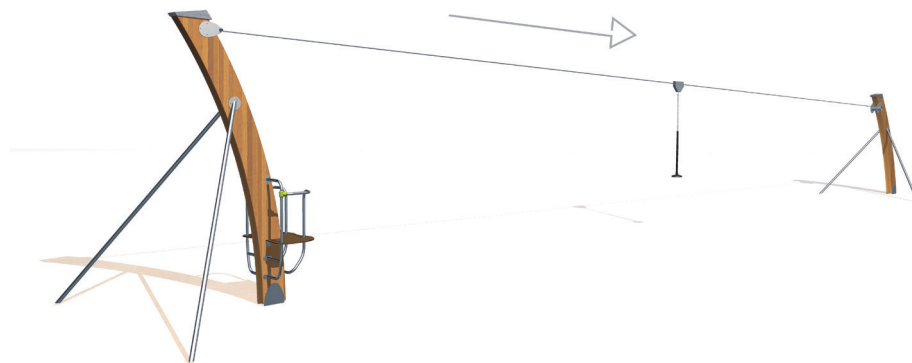

J510/J511 J512/J513 J514/J516

- Check the cable tension (with a 69.5kg load, the seat height must be at least 350 mm from the ground).
- Check that the spring is in working order (with a 69.5kg load, swing the seat out from the starting point, the shock absorber should keep the seat from knocking into the wooden beam).
- Check that the cable is not damaged. Check that none of the wires are cut or have become untwisted.
- Verify the integrity of the LI507 cable attachment fittings.
- Check for wear on the seat chain (if it is worn by more than 1/3 of the wire diameter, replace the chain).



J515/
J2582/
J2582-M

- Ensure that the trolley is moving smoothly on the rail.
- Check wear of part MU442 of the handle. Replace if necessary.

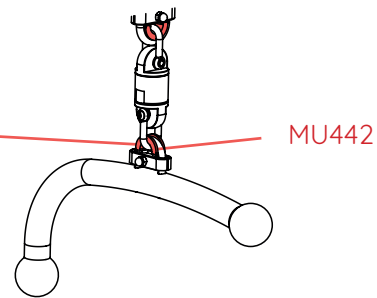
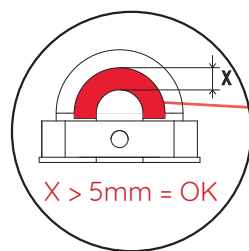

J2581/
J2581-M

- Check wear of part MU442 of the handle. Replace if necessary.
- Check the wear level of the chain on the handles. Replace the parts of the chain if a link is found to be over 1/3 smaller than its original diameter.
- Ensure that the rubber stoppers are in place on each end of the rail.

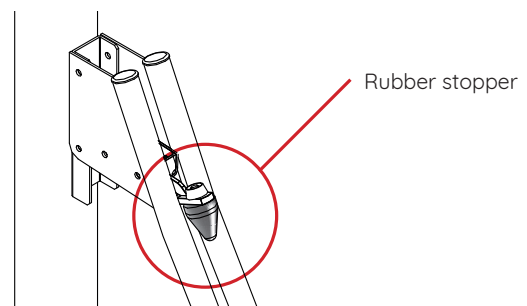
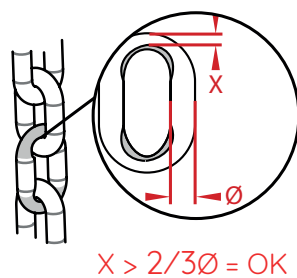

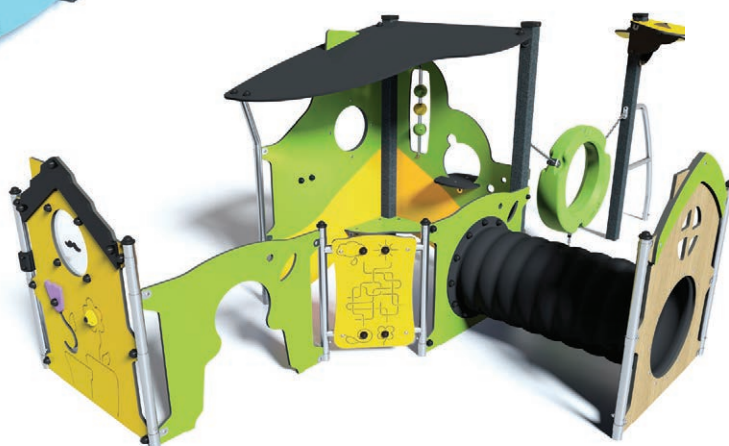

MONTHLY

- Routine visual inspection to identify the risks stemming from acts of vandalism, use or specific weather conditions.
- Ensure all fixings are securely fastened.
- Check for missing or broken parts.
- Ensure that protective covers are in place.
- Check that the wooden posts are free from splinters.
- Use of wood filler to fill any knot holes that could give rise to entrapment of fingers (J4940-J4941).

EVERY 3 MONTHS

- Make sure that the equipment, or the part concerned, is operating correctly.
- Check all fixings.
- Check the stability of the equipment.
- Inspect wear levels (flooring, bars, chains, cables, grips, etc.).

YEARLY

- Inspect the anchoring systems.
- Check the condition of the framework.
- Check that the posts are in good condition.
- Check the general condition of the coloured panels.
- Clean the equipment thoroughly.
- Check that the wooden posts have not split open and that no layers have come unstuck (J254-J256-J4940-J4941).

SWINGS

TRADITIONAL EQUIPMENT



MONTHLY

- Routine visual inspection to identify the risks stemming from acts of vandalism, use or specific weather conditions.
- Ensure all fixings are securely fastened.
- Check for missing or broken parts.
- Ensure that protective covers are in place.
- Check that the wooden posts are free from splinters.
- Use of wood filler to fill any knot holes that could give rise to entrapment of fingers (J4940-J4941 / J490-J491-J499).

EVERY 3 MONTHS

- Make sure that the equipment, or the part concerned, is operating correctly.
- Check all the fixings.
- Check the stability of the equipment.
- Check the swing shackles and chains for wear (if the wear level is greater than 2mm, replace the chains).

YEARLY

- Inspect the anchoring systems.
- Check that the wooden posts have not split open and that no layers have come unstuck.
- Check that the post is in good condition.
- Check the general condition of the coloured panels.
- Check the seat fastenings.
- Clean the equipment thoroughly.
- Check that there is no corrosion on the chains or the linking systems.
- Check wear of components at the chain/seat join. Replace the parts if necessary (see diagrams below).

EVERY 2 YEARS

- Apply a coat of resin varnish to the beam of the J440.

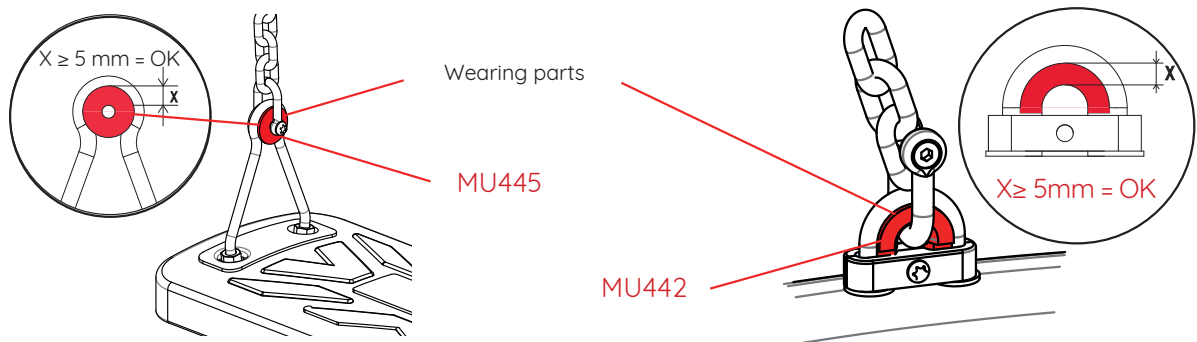

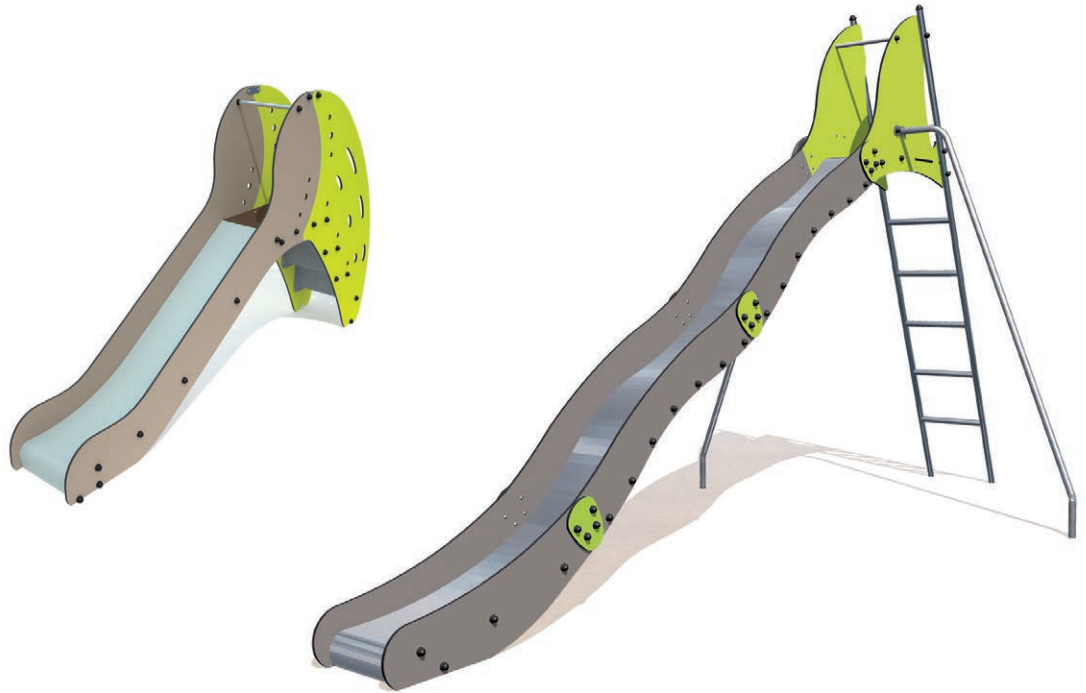

MONTHLY

- Routine visual inspection to identify the risks stemming from acts of vandalism, use or specific weather conditions.
- Ensure all fixings are securely fastened.
- Check for missing or broken parts.
- Ensure that protective covers are in place.

EVERY 3 MONTHS

- Check all the fixings.
- Check the stability of the equipment.
- Check that the lacquered plates are correctly in place to prevent any risk of cords being caught at the top of the slides.
- Ensure that no fibreglass is visible in the case of a polyester slide.

YEARLY

- Inspect the anchoring systems.
- Check the general condition of the coloured panels.
- Clean the equipment thoroughly.

TRAMPOLINES

CLIMBING & BALANCING EQUIPMENT

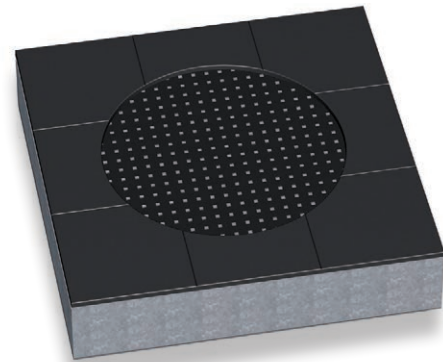
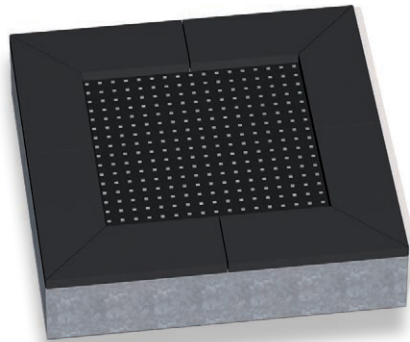

MONTHLY

- Carry out a visual inspection of the jumping surface and the surrounding safety tiles.
- Check that all the springs are in place.

EVERY 3 MONTHS

- Check the pit below the trampoline for any objects which may impede the normal use of the item.
- Ensure the absence of corrosion on the metallic elements.
- Check wear of the jumping surface. Replace if the metal core is visible.

YEARLY

- Check the condition of the surrounding frame.
- Check that all the springs are in place and that they are correctly attached to both the jumping surface and the surrounding frame.
- Check that the surrounding safety tiles are complete and firmly in place.

BALANCING TRAIL

CLIMBING & BALANCING EQUIPMENT

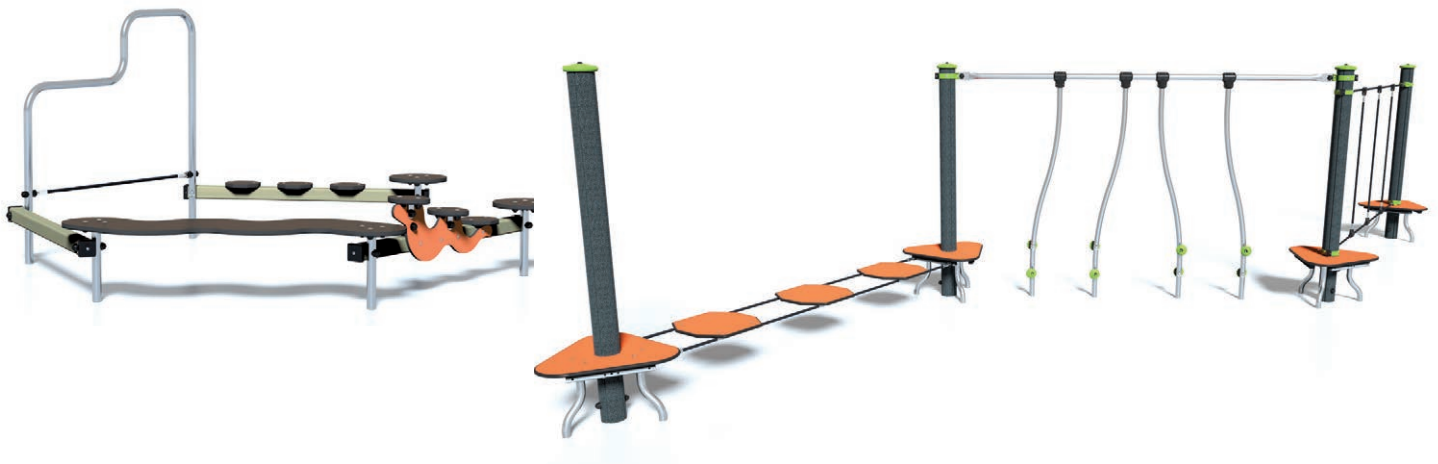

MONTHLY

- Routine visual inspection to identify the risks stemming from acts of vandalism, use or specific weather conditions.
- Ensure all fixings are securely fastened.
- Check for missing or broken parts.
- Ensure that protective covers are in place.
- Check that the wooden posts are free from splinters.

EVERY 3 MONTHS

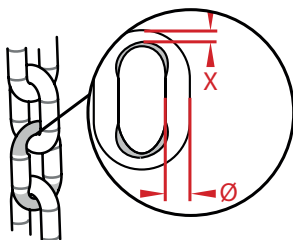

$$X > 2/3\text{Ø} = \text{OK}$$

- Make sure that the equipment, or the part concerned, is operating correctly.
- Check all the fixings.
- Check the stability of the equipment.
- Inspection of the chains and ropes for wear.
- Replace the ropes if the metal core has broken strands.
- Replace the parts of the chain if a link is found to be over 1/3 smaller than its original diameter.

YEARLY

- Inspect the anchoring systems.
- Check the condition of the framework.
- Check that the wooden posts have not split open and that no layers have come unstuck.
- Check that the post is in good condition.
- Check the general condition of the coloured panels.
- Clean the equipment thoroughly.



MONTHLY

- Routine visual inspection to identify the risks stemming from acts of vandalism, use or specific weather conditions.
- Ensure all fixings are securely fastened.
- Check for missing or broken parts.
- Ensure that protective covers are in place.
- Check that the wooden posts are free from splinters.

EVERY 3 MONTHS

- Make sure that the equipment, or the part concerned, is operating correctly.
- Check all the fixings.
- Check the stability of the equipment.
- Inspection of the chains for wear.
- Replace the ropes if the metal core has broken strands.

YEARLY

- Inspect the anchoring systems.
- Check the condition of the framework.
- Check that the wooden posts have not split open and that no layers have come unstuck.
- Check that the post is in good condition.
- Check the general condition of the coloured panels.
- Clean the equipment thoroughly.

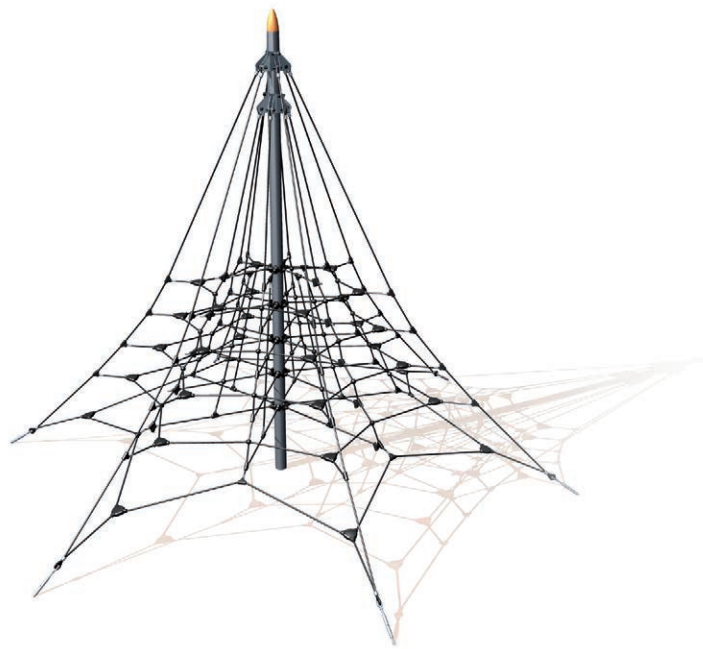

MONTHLY

- Routine visual inspection to identify the risks stemming from acts of vandalism, use or specific weather conditions.
- Ensure all fixings are securely fastened.
- Check for missing or broken parts.
- Ensure that protective covers are in place.

EVERY 3 MONTHS

- Make sure that the equipment, or the part concerned, is operating correctly.
- Check all the fixings.
- Check the stability of the equipment.
- Inspection of the cables for wear.
- Replace the ropes if the metal core has broken strands.

YEARLY

- Inspect the anchoring systems.
- Check the condition of the framework.
- Check that the post is in good condition.
- Clean the equipment thoroughly.
- Tighten the structures if they appear too loose.



MONTHLY

- Routine visual inspection to identify the risks stemming from acts of vandalism, use or specific weather conditions.
- Ensure all fixings are securely fastened.
- Check for missing or broken parts.
- Check that the wooden posts are free from splinters.

EVERY 3 MONTHS

- Check all fixings.
- Check the stability of the equipment.
- Inspect wear levels (flooring, bars, chains, cables, grips, etc.).

YEARLY

- Inspect the anchoring systems.
- Check the condition of the framework.
- Check that the wooden posts have not split open and that no layers have come unstuck.
- Check the general condition of the coloured panels.
- Clean the equipment thoroughly.

THE SUSPENDED WORLD

CLIMBING & BALANCING EQUIPMENT



MONTHLY

- Routine visual inspection to identify the risks stemming from acts of vandalism, use or specific weather conditions.
- Ensure all fixings are securely fastened.
- Check for missing or broken parts.
- Ensure that protective covers are in place.

EVERY 3 MONTHS

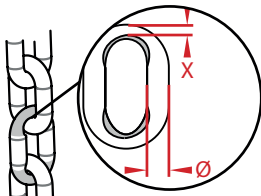

$$X > 2/3 \text{ } \varnothing = \text{OK}$$

- Make sure that the equipment, or the part concerned, is operating correctly.
- Check all fixings.
- Check the stability of the equipment.
- Inspect wear levels (flooring, bars, chains, cables, handles, etc.).
- Replace the ropes if the metal core has broken strands.
- Replace the chain if a link is found to be over 1/3 smaller than its original diameter.

YEARLY

- Inspect the anchoring systems.
- Check the condition of the framework.
- Ensure that the post is in good condition.
- Clean the equipment thoroughly.

G4806

- Check the fixing between the trolley and the rail.
- Check the wear of the part MU442 located on the handle. Replace if necessary.

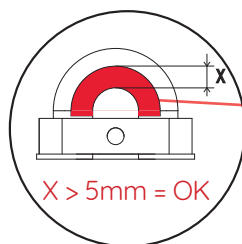
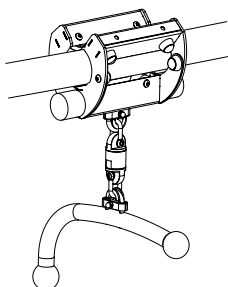

$$X > 5\text{mm} = \text{OK}$$

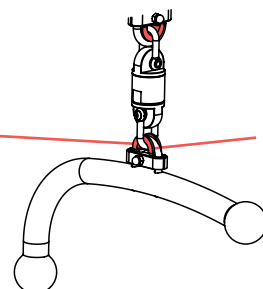

MU442

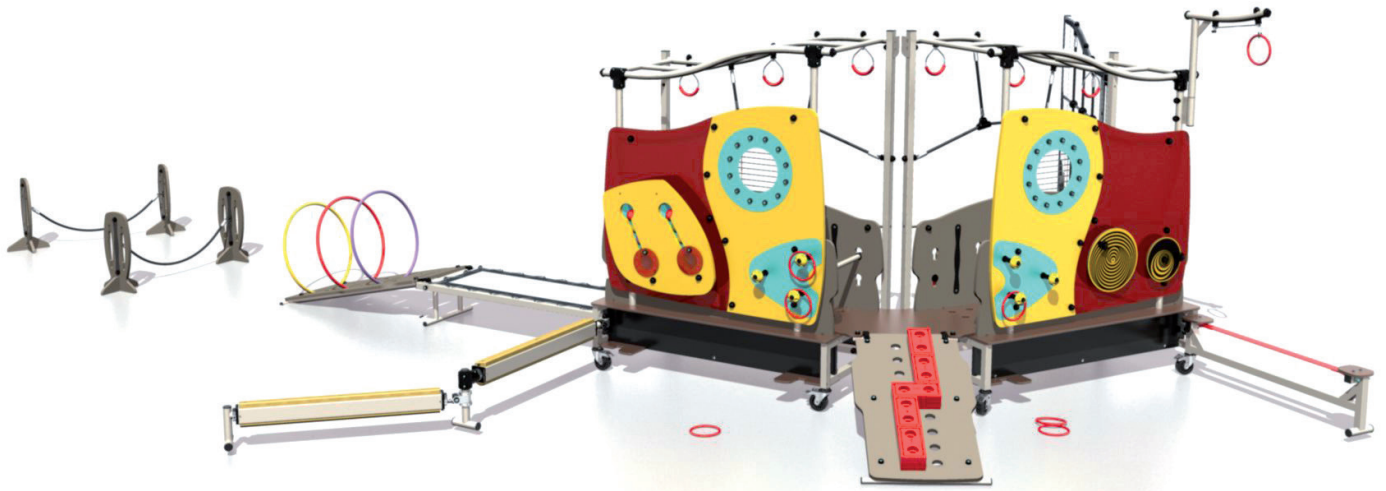

MONTHLY

- Check for missing or broken parts.
- Ensure that protective covers are in place.
- Ensure all fixings are securely fastened.

EVERY 3 MONTHS

- Check there is no corrosion of the metal components.
- Make sure that the equipment, or the part concerned, is operating correctly.
- Inspection of the ropes for wear.
- Inspect attachment of fabric.

YEARLY

- Check the condition of the framework.
- Clean the equipment thoroughly.



MONTHLY

- Routine visual inspection to identify the risks stemming from acts of vandalism, use or specific weather conditions.
- Ensure all fixings are securely fastened.
- Check for missing or broken parts.
- Ensure that protective covers are in place.

EVERY 3 MONTHS

- Make sure that the equipment, or the part concerned, is operating correctly.
- Check all the fixings.
- Check the stability of the equipment.

YEARLY

- Inspect the anchoring systems.
- Check the condition of the framework.
- Check that the post is in good condition.
- Check the general condition of the coloured panels.
- Clean the equipment thoroughly.

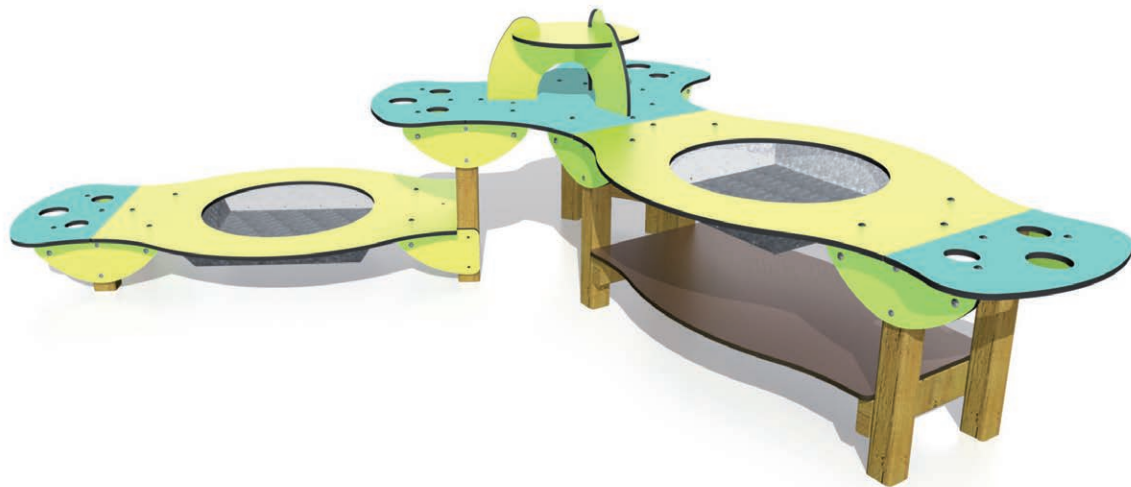

MONTHLY

- Routine visual inspection to identify the risks stemming from acts of vandalism, use or specific weather conditions.
- Ensure all fixings are securely fastened.
- Check for missing or broken parts.
- Ensure that protective covers are in place.
- Check that wooden posts are free from splinters.

EVERY 3 MONTHS

- Check all the fixings.
- Check the stability of the equipment.

YEARLY

- Inspect the anchoring systems.
- Check that the wooden posts have not split open and that no layers have come unstuck.
- Check that the post is in good condition.
- Check the general condition of the coloured panels.
- Check for any leaks.
- Check that the containers are in good condition (checking for any leaks).
- Clean the equipment thoroughly.

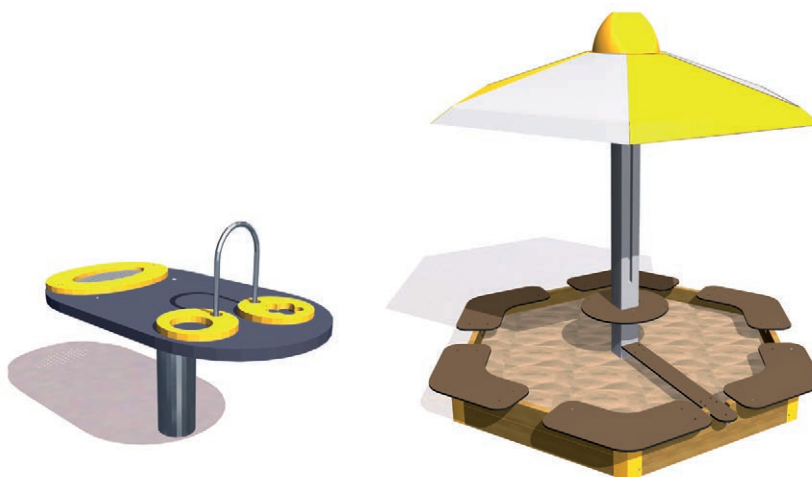

MONTHLY

- Routine visual inspection to identify the risks stemming from acts of vandalism, use or specific weather conditions.
- Ensure all fixings are securely fastened.
- Check for missing or broken parts.
- Ensure that protective covers are in place.
- Check that wooden posts are splinter free.

EVERY 3 MONTHS

- Check that the up-and-down mechanism is functioning correctly (J130)
- Check all the fixings.
- Check the stability of the equipment.

YEARLY

- Inspect the anchoring systems.
- Check that the post is in good condition.
- Check the general condition of the coloured panels.
- Clean the equipment thoroughly.



MONTHLY

- Routine visual inspection to identify the risks stemming from acts of vandalism, use or specific weather conditions.
- Ensure all fixings are securely fastened.
- Check for missing or broken parts.
- Ensure that protective covers are in place.
- Check that wooden posts are splinter free.

EVERY 3 MONTHS

- Check all the fixings.
- Check the stability of the equipment.
- Ensure that the conveyor belt moves freely. If required adjust the tension.

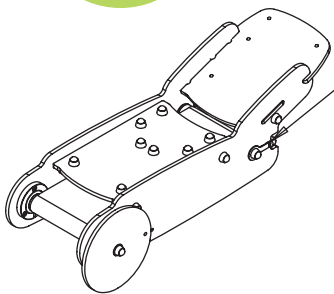

Adjustment of the conveyor belt with the VTH8-30

Tightening = Increasing the belt tension
Loosening = Decreasing the belt tension

- Check the chains on the crane and transporter for excessive wear (Replace the chain if a link is found to be over 1/3 smaller than its original diameter).
- Check the wear of the bearings on the wagon (if the space between the tube and the bearing is $> 6\text{mm}$, change the bearings).

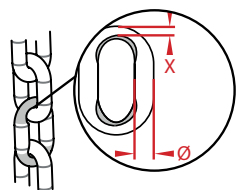

$X > 2/3\varnothing = \text{OK}$

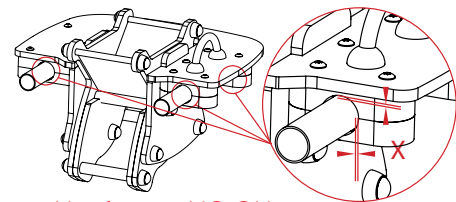

$X > 6\text{mm} = \text{NO OK}$

YEARLY

- Inspect the anchoring systems.
- Check that the wooden posts have not split open and that no layers have come unstuck.
- Check that the post is in good condition.
- Check the general condition of the coloured panels.
- Clean the equipment thoroughly.

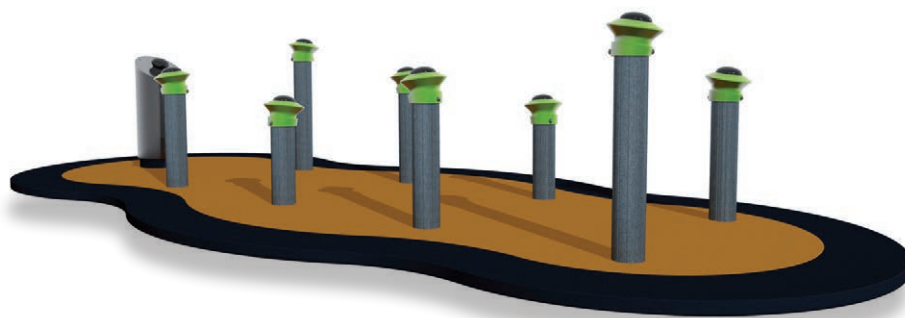

MONTHLY

- Routine visual inspection to identify the risks stemming from acts of vandalism, use or specific weather conditions.
- Ensure all fixings are securely fastened.
- Check for missing or broken parts.
- Ensure that protective covers are in place.
- Functional check to make sure that the equipment, or the part concerned, is operating correctly.

EVERY 3 MONTHS

- Check all the fixings.
- Check the stability of the equipment.

YEARLY

- Inspect the anchoring systems.
- Check that the post is in good condition.
- Clean the equipment thoroughly.
- Adjustment of sound level.



MONTHLY

- Routine visual inspection to identify the risks stemming from acts of vandalism, use or specific weather conditions.
- Ensure all fixings are securely fastened.
- Check for missing or broken parts.

EVERY 3 MONTHS

- Check the state of the fixing element.
- Check the stability of the equipment.
- Tighten the fixings if necessary.
- Clean the equipment thoroughly.

YEARLY

- Inspection of the anchoring systems.
- Check the welds on the post holding the backboard.
- Clean the equipment thoroughly.

EVERY 2 YEARS

- Check the stability of the structures in accordance with the standard EN 15312:2007.



MONTHLY

- Routine visual inspection to identify the risks stemming from acts of vandalism, use or specific weather conditions.
- Ensure all fixings are securely fastened.
- Check for missing or broken parts.
- Ensure that protective covers are in place.

EVERY 3 MONTHS

- Check the movement of the equipment.
- Check the state of the fixing element.
- Check the stability of the equipment.

YEARLY

- Inspection of the anchoring systems.
- Clean the equipment thoroughly.



MONTHLY

- Routine visual inspection to identify the risks stemming from acts of vandalism, use or specific weather conditions.
- Ensure all fixings are securely fastened.
- Check for missing or broken parts.

EVERY 3 MONTHS

- Functional inspection of the various moving parts.
- Check the state of the fixing element.
- Check the stability of the equipment.

YEARLY

- Inspection of the anchoring systems.
- Clean the equipment thoroughly.

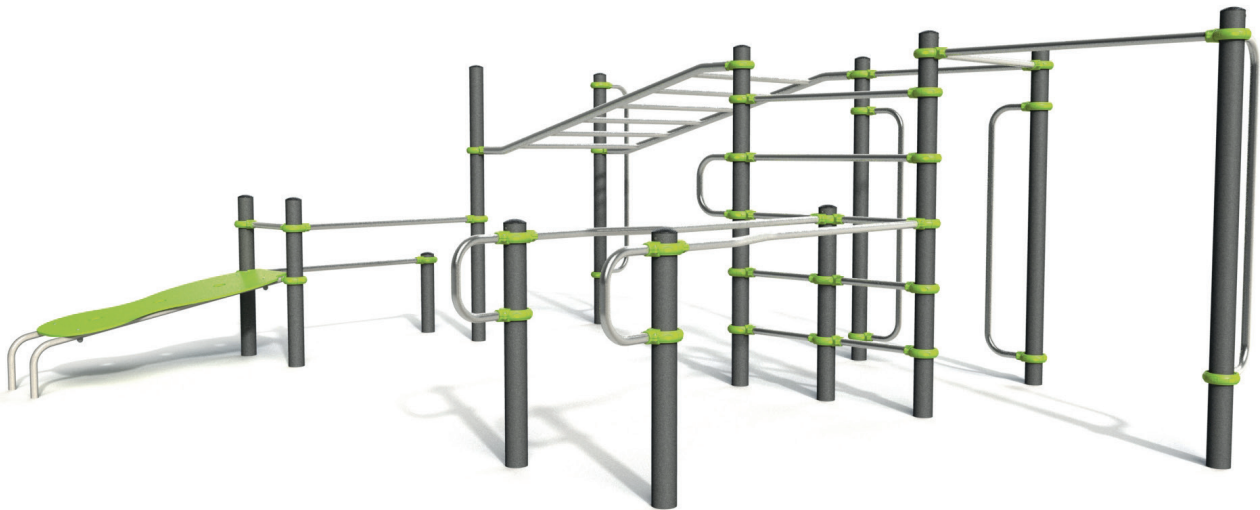

MONTHLY

- Routine visual inspection to identify the risks stemming from acts of vandalism, use or specific weather conditions.
- Ensure all fixings are securely fastened.
- Check for missing or broken parts.

EVERY 3 MONTHS

- Check all the fixings.
- Check the stability of the equipment.
- Tighten the fixings if necessary.
- Clean the equipment thoroughly.

YEARLY

- Inspect the anchoring systems.
- Clean the equipment thoroughly.



MONTHLY

- Routine visual inspection to identify the risks stemming from acts of vandalism, use or specific weather conditions.
- Ensure all fixings are securely fastened.
- Check for missing or broken parts.
- Ensure that the protective covers are in place.
- Check there is no splintering or detachment of strips on the wooden post.

EVERY
3 MONTHS

- Functional inspection of the various moving parts.
- Check the state of the fixings.
- Check the stability of the equipment.
- Tighten the fixings if necessary.
- Clean the equipment thoroughly.

YEARLY

- Inspect the anchoring systems.
- Check there is no splintering or detachment of strips on the beam.
- Clean the equipment thoroughly.



MONTHLY

- Routine visual inspection to identify the risks stemming from acts of vandalism, use or specific weather conditions.
- Ensure all fixings are securely fastened.
- Check for missing or broken parts.
- Ensure that the protective covers are in place.
- Check that the wooden posts have not split open and that no layers have come unstuck.

EVERY 3 MONTHS

- Check the state of the fixings.
- Check the stability of the equipment.
- Tighten the fixings if necessary.

YEARLY

- Inspect the anchoring systems.
- Check there is no splintering or detachment of strips on the beam.
- Clean the equipment thoroughly.



MONTHLY

- Routine visual inspection to identify the risks stemming from acts of vandalism, use or specific weather conditions.
- Ensure all fixings are securely fastened.
- Check for missing or broken parts.
- Ensure that the protective covers are in place.

EVERY 3 MONTHS

- Check the movement of the equipment.
- Check the state of the fixings.
- Check the stability of the equipment.

YEARLY

- Inspect the anchoring systems.
- Check that there is no corrosion on the springs.
- Clean the equipment thoroughly.



MONTHLY

- Routine visual inspection to identify the risks stemming from acts of vandalism, use or specific weather conditions.
- Ensure all fixings are securely fastened.
- Check for missing or broken parts.
- Ensure that the protective covers are in place.

EVERY 3 MONTHS

- Check the movement of the equipment.
- Check the state of the fixing element.
- Check the stability of the equipment.

YEARLY

- Inspect the anchoring systems.
- Check for the wear of the rubber pieces M3507 ensuring that they grip the central tube. Replace if necessary.
- Clean the equipment thoroughly.

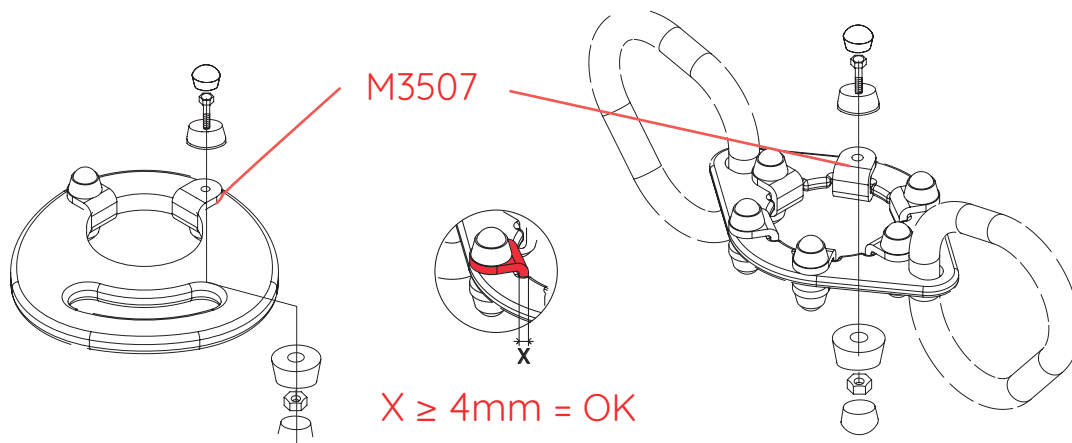



MONTHLY

- Routine visual inspection to identify the risks stemming from acts of vandalism, use or specific weather conditions.
- Ensure all fixings are securely fastened.
- Check for missing or broken parts.
- Ensure that the protective covers are in place.

EVERY 3 MONTHS

- Check the movement of the equipment.
- Check the state of the fixing element.
- Check the stability of the equipment.

YEARLY

- Inspect the anchoring systems.
- Clean the equipment thoroughly.
- Check the wear of the part MU442 located on the handle. Replace if necessary.

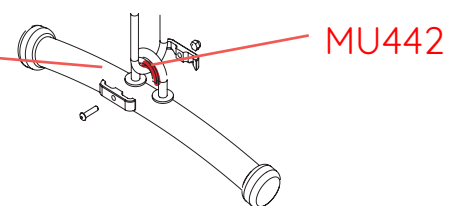
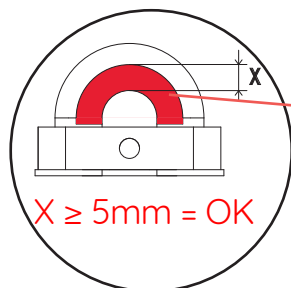



MONTHLY

- Routine visual inspection to identify the risks stemming from acts of vandalism, use or specific weather conditions.
- Ensure all fixings are securely fastened.
- Check for missing or broken parts.
- Ensure that the protective covers are in place.

**EVERY
3 MONTHS**

- Check the movement of the equipment.
- Check the state of the fixing element.
- Check the stability of the equipment.

YEARLY

- Inspect the anchoring systems.
- Clean the equipment thoroughly.
- Check the wear of the part MU442 located on the handle. Replace if necessary.
- Inspect the welds: make sure that no cracking is present on the upper part of the structure.

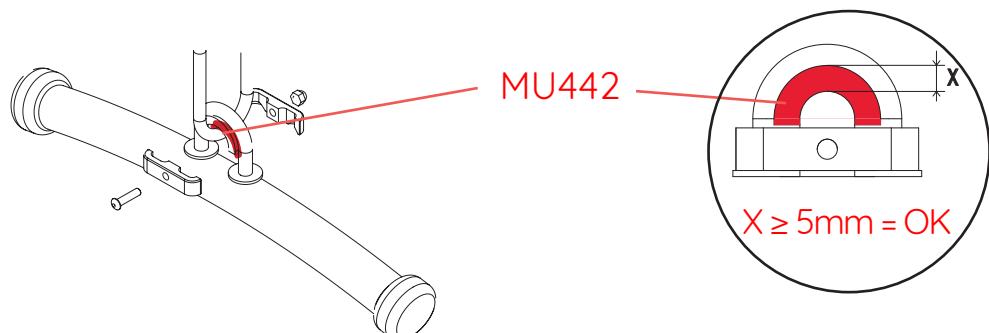



MONTHLY

- Routine visual inspection to identify the risks stemming from acts of vandalism, use or specific weather conditions.
- Ensure all fixings are securely fastened.
- Check for missing or broken parts.
- Ensure that the protective covers are in place.

EVERY 3 MONTHS

- Check the movement of the equipment.
- Check the state of the fixings.
- Check the stability of the equipment.

YEARLY

- Inspect the anchoring systems.
- Clean the equipment thoroughly.
- Check the level of wear and tear on the U2422 shock absorbers according to the method below. Replace if necessary.

1- Place a 20 kg weight on one of the two seats.

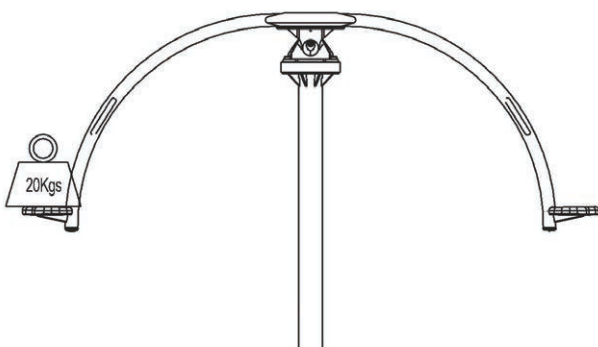

2- Check the upper part tilt angle with regard to the engraved notches.

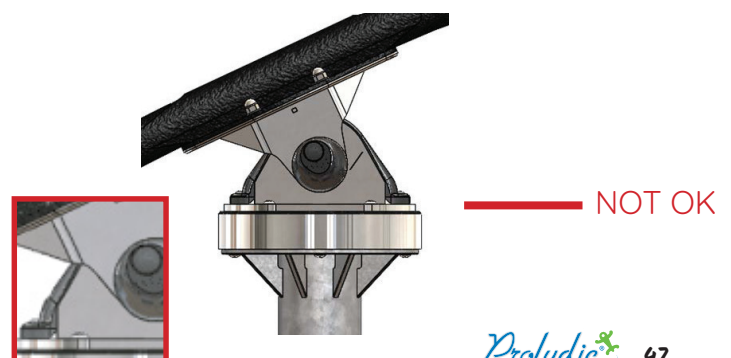
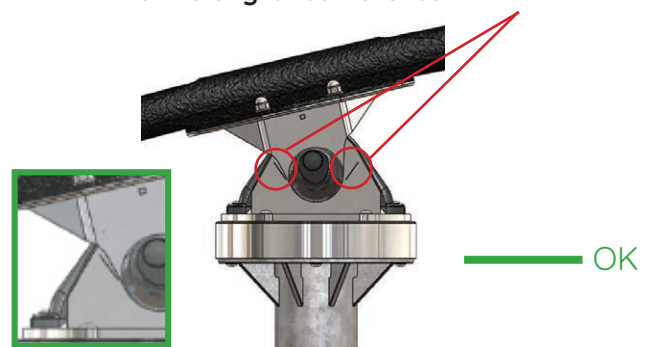

For the equipment versions which do not have the engraved notches, when subjected to a 20 Kg load, the angle must not exceed 20° relative to the vertical.

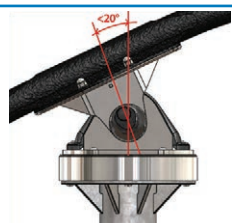



MONTHLY

- Routine visual inspection to identify the risks stemming from acts of vandalism, use or specific weather conditions.
- Ensure all fixings are securely fastened.
- Check for missing or broken parts.

YEARLY

- Inspection of the anchoring systems.
- Thoroughly clean the elements.



MONTHLY

- Routine visual inspection to identify the risks stemming from acts of vandalism, use or specific weather conditions.
- Ensure all fixings are securely fastened.
- Check for missing or broken parts.

YEARLY

- Inspection of the anchoring systems.
- Thoroughly clean the furniture.

European standard EN1176-7:2008 recommends that the playground operator draw up a specific MAINTENANCE SCHEDULE for each playground, taking into account the manufacturers instructions and the local conditions of use.

To do so, we recommended keeping various documents likely to make maintenance easier and ensure that it is rational and efficient.

CONTENT OF OPERATIONS FOLDER

- Layout of the playground (drawn up by the municipal engineering department or the manufacturer).
- Technical data sheets for the equipment items.
- Assembly instructions.
- Certificates of conformity to standards.
- Maintenance schedule issued by the manufacturer.
- Maintenance schedule for each item of equipment.
- Records of the various interventions.
- Accident declaration form.
- Certificate of conformity to installation standards.



Rigorous organisation is essential for efficient maintenance. It ensures optimum durability of playgrounds and their equipment and enables the products to remain in compliance with the standards applicable.



PROLUDIC S.A.S. - 181 rue des Entrepreneurs - 37210 Vouvray - FRANCE
Tél. +33 (0)2 47 40 44 44 - Fax. (+33) 2 47 52 65 55 - E-Mail : proludic@proludic.fr
proludic.com